

# CHEESE GRATERS



**MODEL FGM 111**

**MODEL FGS 101 / FGS 121**

These models allow for easy grating of hard cheese and breads. Designed to be suitable for small to medium applications. The FGM and FGS models feature cast iron grating drums, stainless steel basins and hoppers.

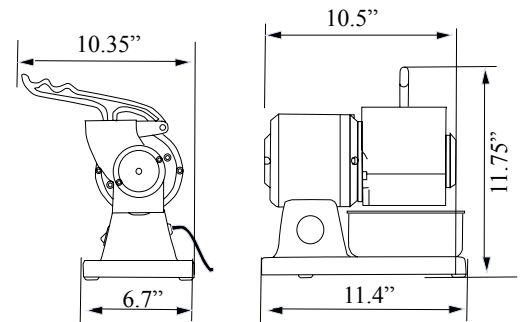

**FGM 111**

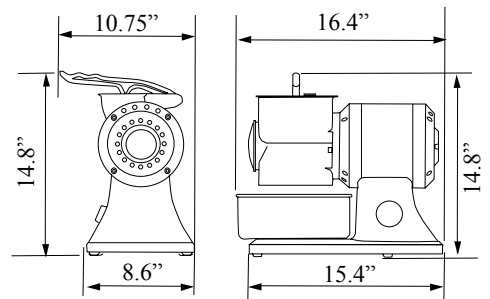

**FGS 101**

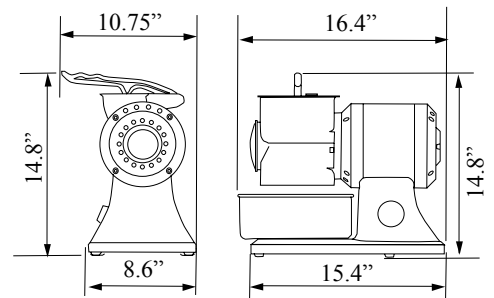

**FGS 121**



## SPECIFICATIONS

Model	Horsepower	Electrical	Weight	Dimensions (LWH)
FGM111	.5 HP	110V/60/1	16 lbs.	10.35" x 11.4" x 11.75"
FGS101	1 HP	110V/60/1	36 lbs.	10.75" x 15.4" x 14.8"
FGS121	1.5 HP	110V/60/1	44 lbs.	10.75" x 15.4" x 14.8"

Authorized Dealer:



**Diverse ♦ Dependable ♦ Proven**

**OMCAN INC.  
FOOD MACHINERY OF AMERICA INC.**

Email: [sales@omcan.com](mailto:sales@omcan.com) ♦ Phone: 1.800.465.0234 or 905.828.0234 ♦ Fax: 905.607.0234